

Model 781 Signal Conditioning Unit

Model 781 is a precision, two-channel signal conditioning unit for all electrolytic tilt sensors. Its design is optimized to produce peak performance from your Applied Geomechanics 755-, 756-, 757- and 758-Series Miniature Tilt Sensors. Model 781 generates a balanced AC sensor excitation, then amplifies, rectifies and filters the sensor outputs to produce high-level DC signals proportional to the tilt angle. It includes an amplifier for an LM35 temperature sensor and will drive tilt and temperature signals over 1000m cable lengths. The rugged aluminum case of Model 781 and its bench-top format make it an effective choice for all laboratory and indoor applications.



Model 781 Signal Conditioning Unit with Model 755-1172 Miniature Tilt Sensor

INPUT CHANNELS	Two electrolytic tilt sensors, one LM-35 temperature sensor (included with tilt sensors)			
TILT OUTPUT	Two single-ended <i>and</i> two differential analog outputs, proportional to tilt: Output voltage range: ± 8 VDC (single-ended), ± 16 VDC (differential)			
OUTPUT GAINS	Two switchable gains, 10:1 ratio standard, other ratios on request			
SCALE FACTORS†	When used with:	High-Gain	Low-Gain	Range
	755-Series Sensors:	0.1 μ radian/mV*	1.0 μ radian/mV	± 8000 μ radians
	756-Series Sensors:	0.1 degree/V	1.0 degree/V	± 8 degrees
	757 & 758-Series Sensors:	1.0 degree/V	10 degrees/V	± 60 & ± 80 degrees
OUTPUT FILTERS	Two switchable low-pass integrators, roll-off = 6 dB/octave. Time constants = 0.05 and 7.5 seconds, other settings on request			
TEMPERATURE OUTPUT	0.1°C/mV (single-ended), -40° to $+100^{\circ}$ C, $\pm 0.75^{\circ}$ C accuracy, 0° C = 0 mV			
OUTPUT IMPEDANCE	270 ohms, short circuit and surge protected			
POWER REQUIREMENTS	± 11 to ± 15 VDC @ $+11$ and -6 mA typical, 250 mV peak-to-peak ripple max., reverse polarity protected			
CONNECTIONS	Dual screw-terminal barrier strips on rear panel			
ENVIRONMENTAL	-25° to $+70^{\circ}$ C operational, -30° to $+100^{\circ}$ C storage; 0 to 90% humidity, noncondensing			
MATERIALS	Painted aluminum case			
SIZE & WEIGHT	3.5 x 5 x 8.4 inches (88 x 127 x 213 mm), 2 lb (0.9 kg)			

* 1 degree = 3600 arc seconds = 17453 μ radians (microradians)

† Single-ended outputs; divide by 2 for differential scale factors.

Ordering Information

Model 781	Signal Conditioning Unit with two tilt channels & one temperature channel
Model D12-200	± 12 Volt DC Power Supply
P/N 81124-03	Spare temperature sensor with 18-inch (450mm) pigtail

Model 781 Signal Conditioning Unit

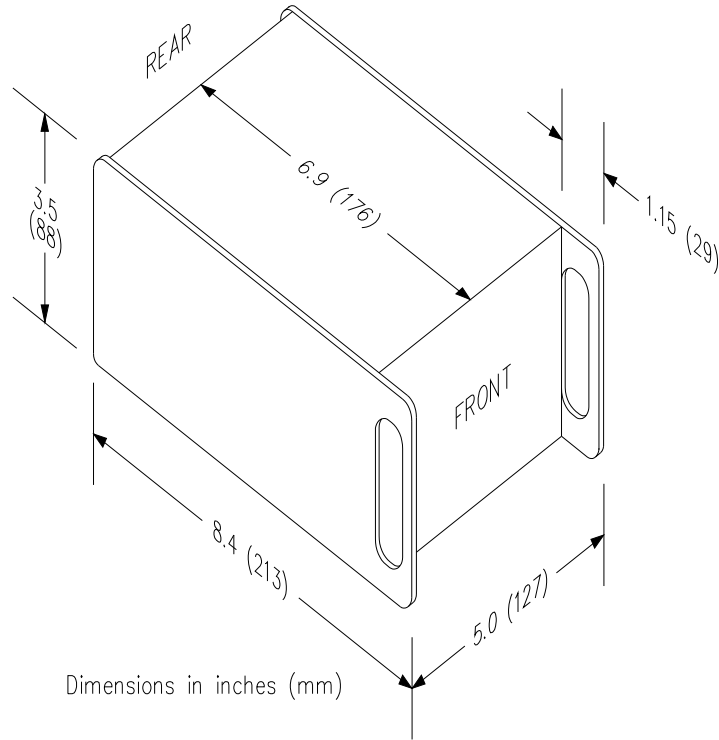

MODEL 781 SIGNAL
CONDITIONING UNIT DIMENSIONS

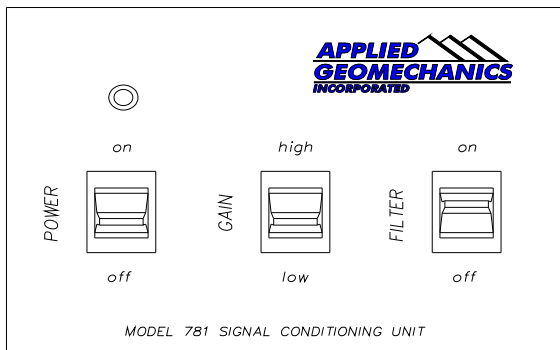

FRONT

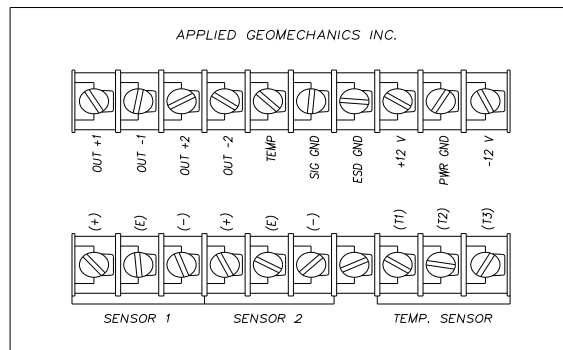

REAR

MODEL 781 SIGNAL CONDITIONING
UNIT, FRONT AND REAR PANELS